

KM 1320 Earth Resistance Soil Resistivity Tester is specially designed and manufactured for measuring earth resistance, soil resistivity, earth voltage, AC voltage. Adopting the latest digital and micro-processing technology, precise 4-pole, 3-pole and simple 2-pole method for earth resistance measurement, importing FFT and AFC technology, with a unique function of anti-interference capability and the ability to adapt to the environment, consistency of repeat testing, to ensure high precision, high stability and reliability for prolonged measure, which is widely used in electric power, telecommunications, meteorology, oil field, construction, lightning protection, industrial electrical equipment and other earth resistance, soil resistivity, earth voltage, AC voltage measurement.

KM 1320 Earth Resistance Soil Resistivity Tester is composed of host machine, monitoring software, testing wires, auxiliary ground pillars, communication wires and others. The large LCD display of host machine is with blue backlight & bar graph indicating that can be seen clearly. At the same time it can store 300 sets of data, fulfilling historical inquiry and online real-time monitoring through monitoring software, dynamic display, alarm indicator, and with the functions like historical data access, reading, preservation, report forms, printing and so on.

**GENERAL SPECIFICATIONS :**

- **Function** : Measurement of 2/3/4-pole earth resistance, soil resistivity, earth voltage, AC voltage
- **Measurement Range** : Earth Resistance: 0.00 - 3 Ω . 0 0
Soil Resistivity: 0.00 -9000k
- **Measuring Mode** : Precise 4-pole measurement, 3-pole measurement, simple 2-pole measurement
- **Measuring Method** : Earth Resistance: rated current change-pole method, measurement current 20mA Max
Soil Resistivity: 4-pole measurement
Earth Voltage: average rectification(between P(S)-ES)
- **Test Frequency** : 128Hz/111Hz/105Hz/94Hz(AFC)
- **Short-circuit Test Current** : AC 20mA max
- **Open-circuit Test Current** : AC 40V max
- **Test Voltage Wave** : Sine wave
- **Electrode Distance Range**: Can be set 1m-100m
- **Shift** : Earth Resistance: 0.00 - 3 Ω . Automatic shift
Soil Resistivity: 0.00 -9000k , automatic shift
- **Backlight** : Blue screen backlight, suitable for dim places
- **Display Mode** : 4-digital super-large LCD display, blue screen backlight
- **Measuring Indicator** : During measurement, LED flash indicator, LCD count down display, progress bar indicator
- **LCD Frame Dimension** : 128mm×75mm
- **LCD Window Dimension** : 124mm×67mm
- **Standard Test Wire** : 4 wires: each for red 20m, black 20m, yellow 10m, and green 10m
- **Simple Test Wire** : 2 wires: each for red 1.6m and black 1.6m
- **Auxiliary Earthing Rod** : 4 rods: 1 \varnothing m×150mm
- **Measuring Rate** : Earth voltage: about 3 times/second
Earth resistance, soil resistivity: about 5 seconds/time
- **Line Voltage** : below AC 600V

All Specifications are subject to change without prior notice

- **Measuring Times** : Over 5000 times (Short-circuit test, interval time should be at least 30 seconds)
- **RS232 Interface** : RS232 interface, software supervision, storage data can be uploaded to computer, saved or printed.
- **Communication Wire** : One piece of RS232 communication wire, with length 1.5m
- **Data Storage** : 300 sets, "MEM" icon storage indicator, flash display "FULL" icon to indicate storage is full
- **Data Hold** : Data hold function: "HOLD" icon display
- **Data Access** : Data read function: "READ" icon display
- **Overflow Display** : Exceeding measuring range overflow function: "OL" icon display
- **Interference Test** : Recognize interference signal automatically, "NOISE" icon display when interference voltage exceed 5V
- **Auxiliary Earthing Test** : Can measure auxiliary earth resistance, 0.00K - 100K (100K < 50k , R+P > 50k)
- **Operating Temperature & Humidity** : -10°C-40°C, below 80%rh
- **Storage temperature & humidity** : -20°C-60°C, below 70%rh
- **Alarm Function** : When measuring value exceeds alarm setting value, there is alarm Sound
- **Battery Voltage** : When battery voltage decreases to about 7.5V, battery voltage low icon will display, reminding to replace battery.
- **Overload Protection** : Measuring earth resistance: between each interfaces of C(H)-E、 P(S)-ES, AC 280V/3 seconds
- **Insulation Resistance** : Over 20M between circuit and enclosure it is 500V)
- **Withstanding Voltage** : AC 3700V/rms (Between circuit and enclosure)
- **Electromagnetic Features** : IEC61326(EMC)
- **Protection Type** : IEC61010-1 (CAT 3V CAT IV 150V、 Pollution 2), IEC61010-031, IEC61557-1 (Earth resistance), IEC61557-5 (Soil resistivity), JJG 366-2004
- **Power Consumption** : Standby: about 20mA (Backlight shut off)
Boot and with backlight: about 45mA (25mA without backlight)
Measurement: about 100mA (Backlight shut off)
- **Power Supply** : DC 9V(Zi-Mn dry battery R14S 1.5V 6 PCS, continuous standby for 300 hours)
- **Weight** : 4.5kg (including package)
- **Dimension** : 215(L)×190(W)×95(H)mm
- **Accessories** : Standard testing wire 4nos., Simple testing wire 2nos., earth rods 4pcs., Battery, Manual Software CD, RS232 Communication cable & Carrying case.

ELECTRICAL SPECIFICATIONS :

1. Base Conditions and Working Conditions

Influence Quantity	Base Condition	Working Conditions
Ambient Temp	23°C±1°C	-10°C-40°C
Ambient Humidity	40%-60%	< 80%
Working Voltage	9V±0.1V	9V±1.5V
Auxiliary Earth Resistance	< 100	< 30
Interference Voltage	no	< 2V
Interference Current	no	< 2A
Electrode Distance when measuring R	a > 5d	a > 5d
Electrode Distance when measuring	a > 20	a > 20

All Specifications are subject to change without prior notice

3. Intrinsic error and performance indicators under base conditions

Category	Measurement Range	Intrinsic Error	Resolution
Earth Resistance(R)	0.00 - 30.00	$\pm 2\% \text{dg} \pm 3\text{dgt}$	0.01
	30.0 - 300.0	$\pm 2\% \text{dg} \pm 3\text{dgt}$	0.1
	300 - 3000	$\pm 2\% \text{dg} \pm 3\text{dgt}$	1
	3.0k0 - 30k.00	$\pm 4\% \text{dg} \pm 3\text{dgt}$	10
Soil Resistivity (ρ)	0.0 - 99.99	According to the precision of R ($\rho = 2R$ a:1 m-100m, = 3 . 1 4)	0.01
	100.0 - 999.9		0.1
	1000 - 9999		1
	10.00k - 99.99k		10
	100.0k - 999.9k		100
	1000k - 9000k		1k
Earth Voltage	AC 0.0-600V	$\pm 2\% \text{rdg} \pm 3\text{dgt}$	0.1V

4. Field Application

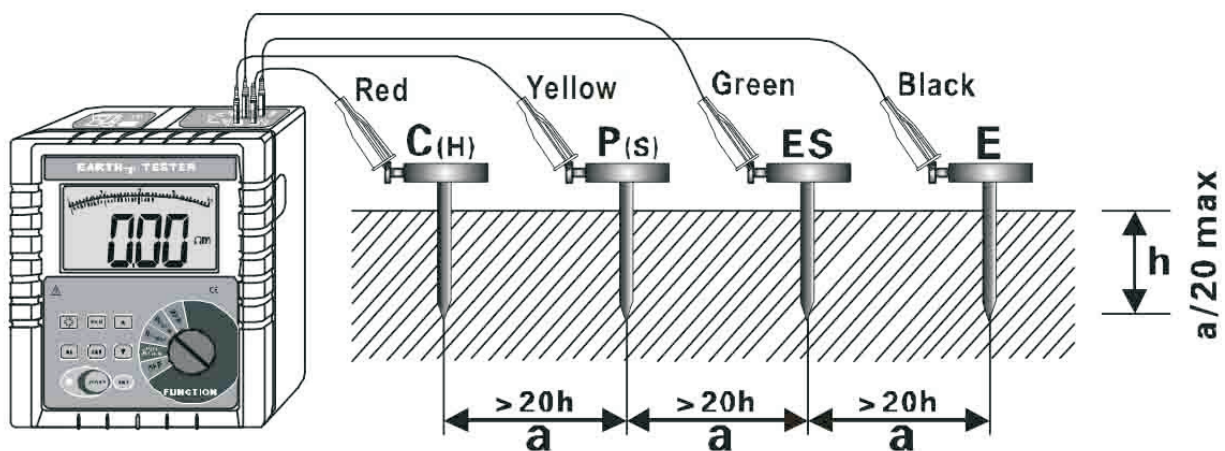
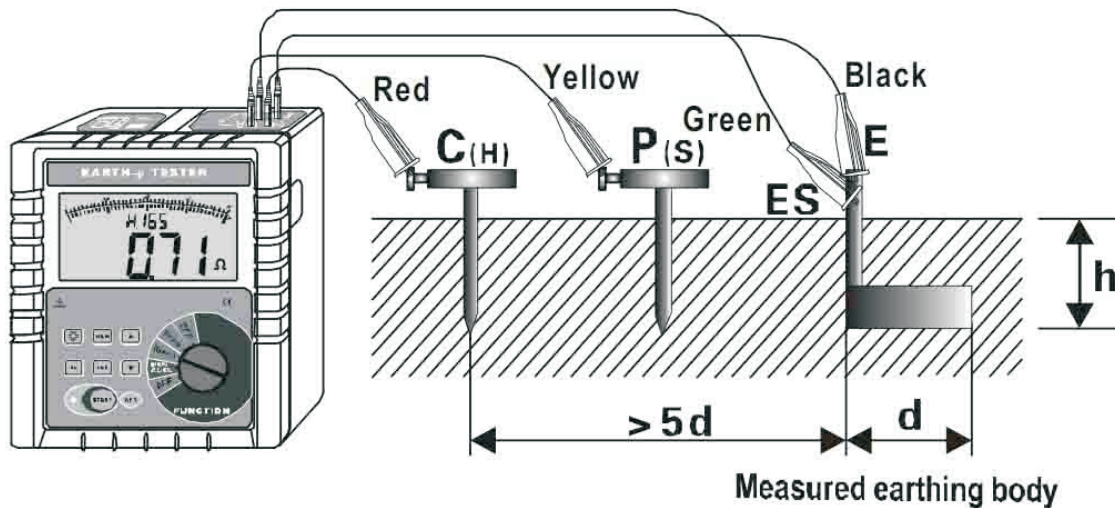

All Specifications are subject to change without prior notice

KUSAM-MECO[®]
An ISO 9001:2008 Company

G-17, Bharat Industrial Estate, T. J. Road, Sewree (W), Mumbai - 400 015. INDIA.
Sales Direct.: 022 -2 4156638, Tel. : 022-24124540, 24181649, Fax : 022 - 24149659
Email : kusam_meco@vsnl.net, Website : www.kusamelectrical.com,



G 17, Bharat Industrial Estate, T. J. Road,
Sewree (W), Mumbai - 400 015. INDIA.

Sales Direct : (022) 24156638

Tel. : (022) 24124540, 24181649. **Fax :** (022) 24149659

Email : kusam_meco@vsnl.net

Website : www.kusamelectrical.com
www.kusam-meco.co.in



AN ISO 9001:2008 COMPANY

**EARTH RESISTANCE
SOIL RESISTIVITY
TESTER**

MODEL - KM 1320

OPERATION MANUAL

KUSAM-MECO®

EARTH RESISTANCE SOIL RESISTIVITY TESTER MODEL - KM 1320



KUSAM-MECO®

CONTENT

Warning.....	1
I. Introduction.....	3
II. Technical Specifications.....	4
1. Base Conditions and Working Conditions.....	4
2. General Specification.....	4
3. Intrinsic error and performance indicators under base conditions.....	6
III. Tester Structure.....	7
IV. LCD Display.....	8
V. Measuring Principle.....	9
VI. Operation Methods.....	10
1. Switch On/Off.....	10
2. Battery Voltage Check.....	10
3. AC Voltage Measurement.....	10
4. Earth Voltage Measurement.....	11
5. 4-wires Precise Earth Resistance Measurement...12	
6. 3-Wires Earth Resistance Measurement.....	13
7. 2-Wires Simple Measurement.....	14
8. Soil Resistivity Measurement.....	15
9. Backlight Control.....	17
10. Alarm Settings.....	17
11. Data Lock/Storage.....	17
12. Data Reading/Deletion.....	17
13. Data Upload.....	18
VII. Battery Replacement.....	18
VIII. Accessories.....	19
IX. Test Certificate.....	20
X. Warranty.....	21

**WARNING**

Thanks for you purchase of **KUSAM-MECO**[®] KM 1320 Earth Resistance Soil Resistivity Tester of our company. For better use of the product, please make sure:

- to read this user manual in details.
- to abide by the safety regulations and precautions strictly.

- ◆ The tester is conforming to IEC61010 on design, production and test.
- ◆ Under any circumstance, it shall pay special attention on safety in use of this tester.
- ◆ Pay attention to words and symbols stick on the Tester.
- ◆ It shall make sure that tester and accessories are in good condition before use; it can be used only when there is no damaged, naked or broken part in testing wires or insulation layer.
- ◆ During measurement, it is forbidden to touch bare conductors and circuit under measurement.
- ◆ Before measurement, please confirm whether **FUNCTION** rotary switch has been set within the proper measuring range.
- ◆ Confirm that connector plug of lead has been inserted in the tester interface closely.
- ◆ Please don't impose over 600V A.C. or D.C. voltage on the part between testing end and interface. Otherwise, it may have damage on the tester.
- ◆ Please don't measure in an inflammable place. The flame sparkle maybe cause explosion.

- ◆ During usage of tester, please stop using it when exposed metal is caused by broken enclosure or testing wires.
- ◆ Please don't keep or store the tester in the spot with high-temperature and moisture, or condensation, and under direct daylight radiation for a long time.
- ◆ If the instrument is damp, please dry it before keeping.
- ◆ For replacing battery, please confirm testing wire has moved apart the meter, and **FUNCTION** rotary switch is in "OFF" position.
- ◆ Please put the used batteries in appointed collection place.
- ◆ The Tester has no auto shut-off function. Please set **FUNCTION** rotary switch to "OFF" after usage.
- ◆ When the meter displays battery low voltage symbol , and you need to replace the battery in time.
- ◆ If the Tester is not going to be used for a long period, remove the battery.
- ◆ Pay attention to measuring range and usage environment stipulated for the Tester.
- ◆ This measuring device is only to be used, disassembled, adjusted and repaired by qualified personnel with authorization.
- ◆ When it may cause hazard by continuous use for the reason of the Tester itself, it shall immediately stop using it and deposit it at once, leaving it for disposal by authorized agency.
- ◆ For risk of danger icon in manual "⚠", users must perform safety operations strictly in compliance with the manual content.

I. INTRODUCTION :

KUSAM-MECO[®] **KM 1320 Earth Resistance Soil Resistivity Tester** is specially designed and manufactured for measuring earth resistance, soil resistivity, earth voltage, AC voltage. Adopting the latest digital and micro-processing technology, precise 4-pole, 3-pole and simple 2-pole method for earth resistance measurement, importing FFT and AFC technology, with a unique function of anti-interference capability and the ability to adapt to the environment, consistency of repeat testing, to ensure high precision, high stability and reliability for prolonged measure, which is widely used in electric power, telecommunications, meteorology, oil field, construction, lightning protection, industrial electrical equipment and other earth resistance, soil resistivity, earth voltage, AC voltage measurement.

KUSAM-MECO[®] **KM 1320 Earth Resistance Soil Resistivity Tester** is composed of host machine, monitoring software, testing wires, auxiliary ground pillars, communication wires and others. The large LCD display of host machine is with blue backlight and bar graph indicating that can be seen clearly. At the same time it can store 300 sets of data, fulfilling historical inquiry and online real-time monitoring through monitoring software, dynamic display, alarm indicator, and with the functions like historical data access, reading, preservation, report forms, printing and so on.

KUSAM-MECO[®] **KM 1320 Earth Resistance Soil Resistivity Tester** also named : Precise Earth Resistance Tester, 4-pole Earth Resistance Tester, 2/3/4-pole Earth Resistance Tester, Soil Resistivity Tester.

II. TECHNICAL SPECIFICATIONS :

1. Base Conditions and Working Conditions :

Influence Quantity	Base Condition	Working Condition	Remark
Ambient Temp	23°C ± 1°C	-10°C-40°C	----
Ambient Humidity	40%-60%	<80%	----
Working Voltage	9V ± 0.1V	9V ± 1.5V	rC, rP
Auxiliary Earth Resistance	<100	<30	----
Interference Voltage	no	<20V	----
Interference Current	no	<2A	
Electrode Distance when measuring R	a>5d	a>5d	----
Electrode Distance when measuring P	a>20h	a>20h	----

2. GENERAL SPECIFICATION :

Function	Measurement of 2/3/4-pole earth resistance, soil resistivity, earth voltage, AC voltage
Power Supply	DC 9V (Zi-Mn dry battery R14S 1.5V 6 PCS, continuous standby for 300 hours)
Measurement Range	Earth Resistance : 0.00 -30.00k Soil Resistivity : 0.00 m-9000k m
Measuring Mode	Precise 4-pole measurement, 3-pole measurement, simple 2-pole measurement
Measuring Method	Earth Resistance : rated current change-pole method, measurement current 20mA Max Soil Resistivity : 4-pole measurement (Wenner method) Earth Voltage : average rectification (between P(s)-ES)
Test Frequency	128Hz/ 111Hz/ 105Hz/ 94Hz (AFC)
Short-circuit Test Current	AC 20mA max
Open-circuit Test Current	AC 40V max
Test Voltage Wave	Sine wave
Electrode Distance Range	Can be set 1m-100m

Shift	Earth Resistance : 0.00 -30.00k , automatic shift Soil Resistivity : 0.00 m-9000k m, automatic shift
Backlight	Blue screen backlight, suitable for dim places
Display Mode	4-digital super-large LCD display, blue screen backlight
Measuring Indicator	During measurement, LED flash indicator, LCD count down display, progress bar indicator
LCD Frame Dimension	128mm 75mm
LCD Window Dimension	124mm 67mm
Dimension	L W H : 215mm 190mm 95mm
Standard Test Wire	4 wires : each for red 20m, black 20m, yellow 10m, and green 10m
Simple Test Wire	2 wires : each for red 1.6m and black 1.6m
Auxiliary Earthing Rod	4 rods : 10mm 150mm
Measuring Rate	Earth voltage : about 3 times/ second Earth resistance, soil resistivity : about 5 seconds/ time
Measuring Times	Over 5000 times (Short-circuit test, interval time should be at least 30 seconds)
Line Voltage	below AC 600V
RS 232 Interface	Possess Rs232interface, software supervision, storage data can be uploaded to computer, saved or printed.
Communication Wire	One piece of Rs232 communication wire, with length 1.5m
Data Storage	300 sets, "MEM" icon storage indicator, flash display "FULL" icon to indicate storage is full
Data Hold	Data hold function : "HOLD" icon display
Data Access	Data read function : "READ" icon display
Overflow Display	Exceeding measuring range overflow function : "OL" icon display
Interference Test	Recognize interference signal automatically, "NOISE" icon display when interference voltage exceed 5V
Auxiliary Earthing Test	Can measure auxiliary earth resistance, 0.00k -30k (100R + rC<50k , 100R + rP<50k)
Alarm Function	When measuring value exceeds alarm setting value, there is "Toot-toot-toot" alarm hint

Battery Voltage	When battery voltage decreases to about 7.5V, battery voltage low icon  will display, reminding to replace battery.
Power Consumption	Standby : about 20mA (Backlight shut off)
	Boot and with backlight about 45mA (25mA without backlight)
	Measurement : about 100mA (Backlight shut off)
Weight	Total weight : 4.5kg (including package)
	Tester : 1443g (including battery)
	Testing wires : 1560g Auxiliary earthing rods : 935g (4pcs)
Working Temperature & Humidity	-10°C-40°C, below 80%rh
Storage Temperature & Humidity	-20°C-60°C, below 70%rh
Overload Protection	Measuring earth resistance : between each interfaces of C(H)-E, P(S)-ES, AC 280V/3 seconds
Insulation Resistance	Over 20M (between circuit and enclosure it is 500V)
Withstanding Voltage	AC 3700V/rms (Between circuit and enclosure)
Electromagnetic Features	IEC61326 (EMC)
Protection Type	IEC61010-1 (CAT III 300V, CAT IV 150V, Pollution 2), IEC61010-031, IEC61557-1 (Earth resistance), IEC61557-5 (Soil resistivity), JJG 366-2004

3. Intrinsic error and performance indicators under base conditions

Category	Measurement Range	Intrinsic Error	Resolution
Earth Resistance (R)	0.00 -30.00k	$\pm 2\%rdg \pm 3 dgt$	0.01
	30.0 -300.0k	$\pm 2\%rdg \pm 3 dgt$	0.1
	300 -3000k	$\pm 2\%rdg \pm 3 dgt$	1
	3.00 -30.00k	$\pm 4\%rdg \pm 3 dgt$	10
Soil Resistivity ()	0.00 -99.99k	According to the precision of R (= 2 aR a : 1 m-100m, = 3.14)	0.01 m
	100.0 -999.9k		0.1 m
	10000 -9999k		1 m
	10.00 -99.99k		10 m
	100.0 -999.9k		100 m
Earth Voltage	AC 0.0-600V	$\pm 2\%rdg \pm 3 dgt$	0.1V

Note :

1. When **rC** max or **rP** max, additional error $< \pm 3\%rdg \pm 5 dgt$.
(**rC** max : 4k + 100R <50k , **rP** max : 4k + 100R <50k)
2. When 5V interference voltage, additional error $< \pm 5\%rdg \pm 5dgt$.

III. TESTER STRUCTURE :

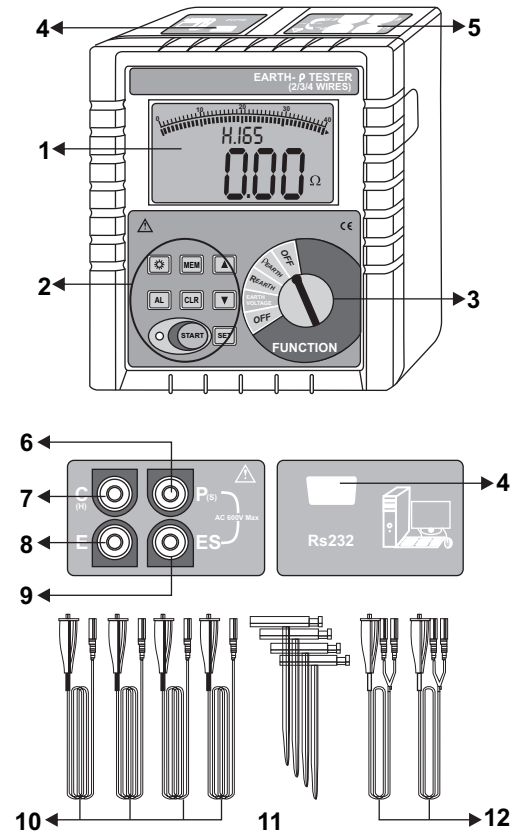

- | | |
|--|--------------------------------------|
| 1. LCD | 2. Button area |
| 3. Rotary switch for selecting function | 4. RS232 interface |
| 5. Interface of testing wires | 6. P(S) interface: Voltage electrode |
| 7. C(H) interface: Current electrode | 8. E interface: Earth electrode |
| 9. ES interface: Auxiliary earth electrode | 10. Standard test wires |
| 11. Auxiliary earthing rods | 12. Simple test wires |

IV. LCD DISPLAY :

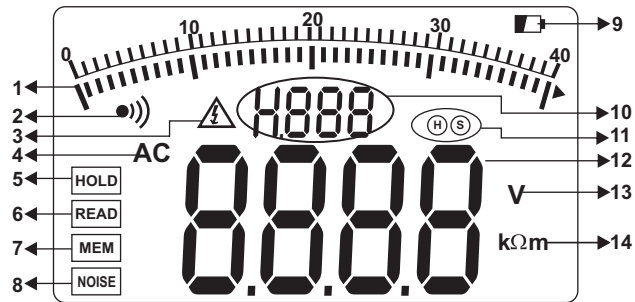

1. Progress bar (Dynamic display the progress of testing)
2. Alarm symbol (Display when open alarm function, flash when exceed the alarm value)
3. Exceed voltage symbol (Display when the measured voltage exceed 30V, please pay attention to the safety)
4. AC symbol
5. Data hold symbol (Display when press **MEM** to hold data)
6. Data access symbol (Display when long press **MEM** for at least 3 seconds to access data)
7. Data storage symbol (Display when press **MEM** to hold data and store)
8. Interference signal symbol (Display when the interference voltage exceed 5V)
9. Low battery symbol (Display when the battery voltage decreases to 7.5V)

10. Display the group number of stored data, and display countdown.
11. Interference electrode symbol (Display when the electrode exceed 5V interference voltage)
12. Measured data
13. Voltage unit symbol
14. Resistance, soil resistivity, length unit symbol (, k , m, k m, m)

V. MEASURING PRINCIPLE :

1. Voltage to ground measurement adopts average value rectification method.
2. Earth resistance measurement with fall-of-potential method. AC constant current **I** is applied between the measurement object **E** earth electrode and **C(H)** current electrode, and finding out the potential difference **V** between **E** earth electrode and **P(S)** voltage electrode, calculating the earth ground **R** according to formula $R = V/I$. To ensure the accuracy of test, designed the 4-wires method can eliminate influence of contact resistance (usually result from dirty or rusty) between measured earthing body, auxiliary earthing rods, test clips, meter's input interface. The 4-wires method can also eliminate influence of line resistance.

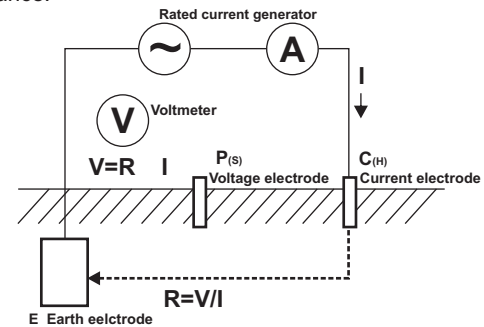

3. **Maximum Operating Error** : Operating error (B) is an error obtained within the rated operating conditions, and calculated with the intrinsic error (A), which is an error of the instrument used, and the error (E) due to variations.

$$B = \pm (|A| + 1.15 \sqrt{E_2^2 + E_3^2 + E_4^2 + E_5^2})$$

- A : Intrinsic error
- E2 : Variation due to power supply voltage
- E3 : Variation due to temperature change
- E4 : Variation due to interference voltage change
- E5 : Variation due to contact electrode resistance

4. **Soil resistivity () is measured by 4-pole method (Wenner method)** : There is a AC current I between E earthing electrode and C(H) current electrode, find the potential difference V between P(s) voltage electrode and ES auxiliary earthing electrode, the potential difference V divided by AC current I is earth resistance R, electrode distance is a(m), then soil resistivity can be got according to formula $\rho = 2 aR(m)$. If the electrode distance of C(H)-P(s) is equal to P(s)-ES (both is a) that is for wenner method. In order to simple the calculation, please make electrode distance a far more than embedding depth h, generally should meet $a > 20h$, as shown below.

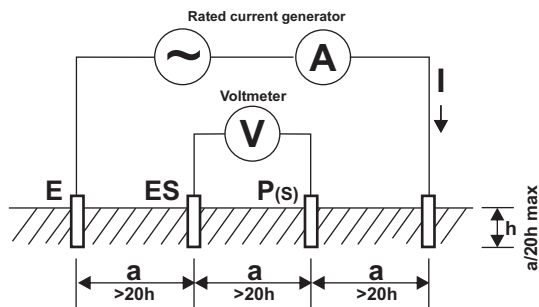

VI. OPERATION METHODS :

1. Switch On/Off :

Rotate **FUNCTION** rotary switch to fulfill switch on and off. When rotary switch button displays "OFF" for shut-off. The Tester has no auto shut-off function, so please shut it off after usage in case of battery consumption saving.

2. Battery Voltage Check :

After switch on, if LCD displays low battery voltage icon "  ", which indicates that battery voltage is low, and please replace the battery in compliance with instructions. Adequate battery power can ensure the accuracy of measurement.

3. AC Voltage Measurement :



**Ac line voltage measurement can't exceed 600V.
Connect P(s) and ES interface to test commercial AC voltage, no need to connect C(H) and E interface.**

AC voltage measurement refers to the general commercial AC voltage measurement, pay attention to the difference between earthing voltage, the meter can be used for testing below 600V AC line voltage.

As shown below. Firstly connect test wires with P(s), ES interface, secondly connect test wires with tested line, then rotate **FUNCTION** rotary switch to "EARTH VOLTAGE" and start testing, LCD will display the test results.

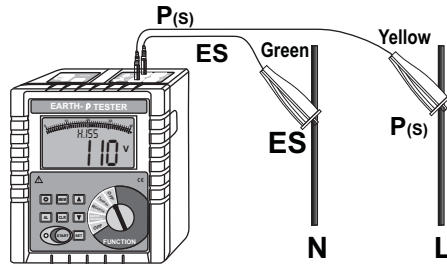

4. Earth Voltage Measurement :

⚠ Earth voltage measurement need to use one auxiliary earthing rod.
 The meter connect with the earth only by testing wires and auxiliary earthing rods. Other tester wires of meter's interface can't connect with commercial power line L, N, otherwise may cause leakage, the breaker may start, it is dangerous.
 Earth voltage measurement can't exceed 600V.

Earth voltage : That is a potential differences between zero potential differences and earthing equipment shell, earthing wires, earthing body when electrical equipment has a earthing fault. Earth voltage is the potential differences between the earth. As a reference point, the earth is zero potential.

Earth voltage measurement need to use one auxiliary earthing rod. Please pay attention to the difference from commercial AC voltage measurement. As shown below : meter, auxiliary earthing rods, testing wires are all connected, rotate **FUNCTION** rotary switch to "EARTH VOLTAGE" and start testing, LCD will display the test results.

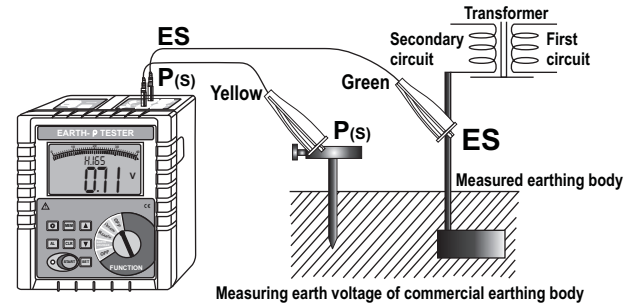

5. 4-wires Precise Earth Resistance Measurement :

⚠ In the testing of earth resistance, should firstly confirm the earth voltage of earthing wire, the voltage between C(H) and E or P(s) and ES must under 20V, the meter showing **NOISE** symbols when the earth voltage exceed 5V, and the measured value of earth resistance may produce error. At this time, firstly interrupt power supply to earthing equipment, make sure the earth voltage decrease, and then test earth resistance again.

4-wires Measurement : The 4-wires method can eliminate influence of contact resistance (usually result from dirty or rusty) between measured earthing body, auxiliary earthing rods, test clips, meter's input interface. The 4-wires method can also eliminate influence of line resistance. So it is better than 3-wires measurement.

As shown below : Start from the measured body, interval 5m-20m, respectively insert P(s), C(H) auxiliary earthing rods deep into the earth in a straight line, and then connect testing wires (black, green, yellow, red) from E, ES, P(s), C(H) interfaces corresponding to measured earth electrode E, auxiliary voltage electrode P(s), auxiliary current electrode C(H).

The distance from measured earthing body to current electrode C(H), should at least five times longer than the embedded depth of measured earthing body, or the embedded electrode depth (d).



When measuring the total earth resistance of complex earthing system, d is the length of the biggest diagonal line of this earthing system.

Testing wires can't be winded together, or may affect the measuring accuracy.

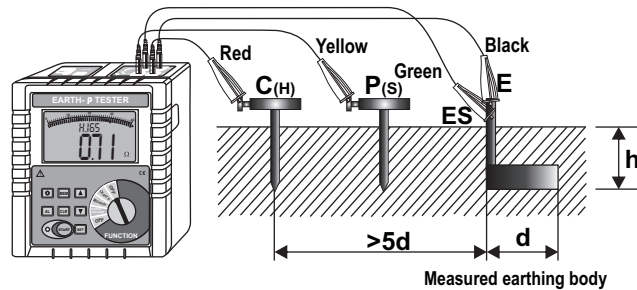

For multi independent earthing system or larger earth net, 50m or larger testing wire is optional, as shown below :

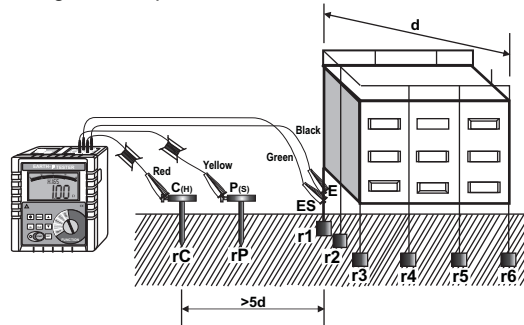

$R = r1/r2/r3/r4/r5/r6/.../rn$ ($r1...rn$ are all independent earthing points)

R— The reading value on meter, the total earth resistance of the earthing system.

$r1...rn$ — All are independent earthing points, each points have no connection together under the ground.

rC— The earth resistance **rC** of auxiliary current electrode C(H).

rP— The earth resistance **rP** of auxiliary voltage electrode P(s).

n— Number of independent earthing point, more points, smaller the **R** value.

After finishing wires connection, firstly rotate **FUNCTION** rotary switch to "REARTH", press "START" button to start testing. During testing, display countdown and process bar indicator. Stable earth resistance value is shown when finish testing.

Press "SET" button, the earth resistance **rC** of auxiliary current electrode C(H) and earth resistance **rP** of auxiliary voltage electrode P(s) will be displayed, and then automatically return display of measured earth resistance **R**.

As shown below, the measured earth resistance is 2.05 , already stored 8 sets of data. The earth resistance **rC** of auxiliary current electrode C(H) is 0.36K , the earth resistance **rP** of auxiliary voltage electrode P(s) is 0.27K .



6. 3-Wires Earth Resistance Measurement :

3-wires measurement : As shown below, short-circuit ES and S interface, which is 3-wires measurement. The operation of meter is the same with 4-wires measurement. The 3-wires method can't eliminate influence of line resistance, also can't eliminate influence of contact resistance between meter and testing wires, testing wires and auxiliary earthing rods. Meanwhile, oxidation layer on measured earthing body must be removed when measuring.

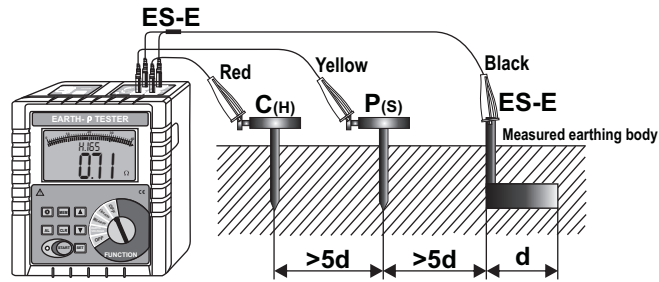

7. 2-Wires Simple Measurement :

When select commercial use power supply system earth as auxiliary earth electrode, it must use detector to confirm that is it the earth ground electrode for commercial use power supply system, otherwise the breaker may start, it is dangerous.



Using 2-wires simple method for measuring earth resistance, try to choose a earthing body which has a small r_e value as auxiliary earthing electrode, so that the reading value is more close to the real value. The metal pipes, metal fire hydrant have priority in choosing auxiliary earthing electrodes.

2-wires method : This method is a simple method for measurement that does not use auxiliary earthing rod, taking the earth electrode with the minimal existing earth ground resistance value as auxiliary earth electrode, and connecting by two simple testing wires (in which $C(H)-P(S)$, $E-ES$ interfaces are in short circuit). It can make use of metal pipes, fire hydrants and other metal buried objects, common earthing of commercial electric power system or lightning protection earth ground electrode and others to replace auxiliary earthing rods $C(H)$, $P(S)$, and pay attention to remove oxide layer on the connection point of the selected metal auxiliary earthing objects when making measurement.

Wire connection is as following figure, and refer to 4-wires measurement for other operations.

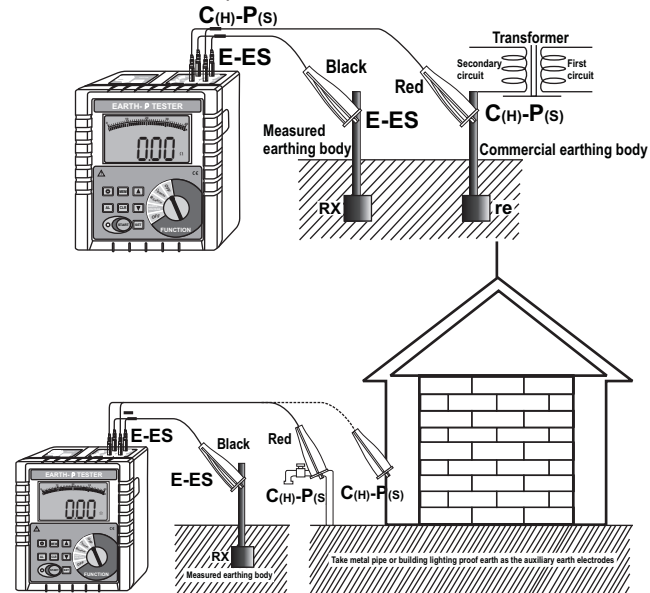

2-wires simple method for measurement of earth ground resistance, its reading on tester is the total value of earth ground resistance value of measured earthing object and that of commercial earthing object, that is : $R = RX + re$

In which :

R is the tester reading value;

RX is the earth ground resistance value of measured earthing object;

re is the earth ground resistance value of common earthing object like commercial use power system.

Then, the earth ground resistance value of measured earthing object is : $RX = R - re$

8. Soil Resistivity Measurement :

Soil resistivity ρ is a determining factor of earthing resistance of earthing body. Different nature of the soil, there is a different soil resistivity. Even the same kind of soil, due to different temperature and water content and so on, the soil resistivity will correspondingly have a significant change. Therefore, in order to have a correct basis in the design of the earthing device, ensure the designed earthing device be more in accord with the need of practical work, soil resistivity measurement is very essential.

Soil resistivity is measured by 4-pole method (Wenner method)

According to formula $\rho = 2\pi a R(\Omega m)$ calculating soil resistivity ρ , its unit is Ωm , in which :

a—electrode distance

R—soil resistivity between electrode **P(s)**-**ES**

4-pole method (Wenner method) : Connect testing wires as shown below, pay attention to the distance between auxiliary earthing rods, and the embedding depth. Respectively insert **C(H)**, **P(s)**, **ES**, **E** auxiliary earthing rods deep into the earth in a straight line, and then connect testing wires (red, yellow, green, black) corresponding to **C(H)**, **P(s)**, **ES**, **E** of interfaces and measured auxiliary earthing rods.

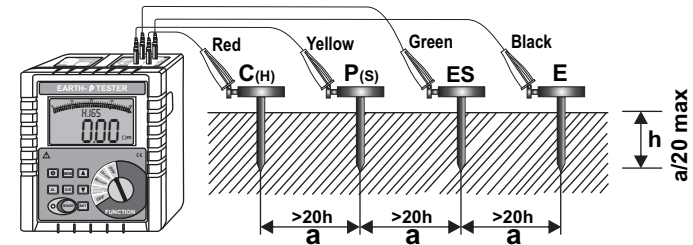

Setting distance between auxiliary earthing rods : After finishing wires connection, firstly rotate **FUNCTION** rotary switch to “**pEARTH**”, long press “**SET**” button (about 3 seconds) to enter setting, short press “**SET**” button to move the cursor, press “**▲**” or “**▼**” button to change current data value (a range:1m-100m), then long press “**SET**” button to save the set a value, and return soil resistivity testing mode.

After setting a value, in soil resistivity testing mode, press the “**START**” button to start testing, and countdown display testing process, stable soil resistivity value is shown when finish testing.

As shown below, the measured soil resistivity is 53.38 Ωm , already stored 157 sets of data. Press “**SET**” button, the earth resistance **rC** of auxiliary current electrode **C(H)** and earth resistance **rP** of auxiliary voltage electrode **P(s)** will be displayed, and then automatically return display of measured soil resistivity ρ .



9. Backlight Control :

After startup, press “☼” button to turn on or off backlight. The backlight function is suitable to dark spot, power consumption of backlight is about 25mA. It will default backlight turn-off for each startup.

10. Alarm Settings :

After startup, rotate **FUNCTION** rotary switch to select function, press “AL” button for a brief time to open or shut off alarm function, press “AL” button for a long time (about 3 seconds) to enter alarm critical value settings, press “▲” or “▼” to change current digital, press “AI” button to move cursor and then press “AI” button to store and exit. When measurement value is larger than alarm critical settings value and it has opened alarm function, the tester will flash and display “●)”) icon and give out “toot-toot-toot--” alarming sound.

11. Data Lock / Storage :

In test mode, press “MEM” button for a brief time to lock current displayed data, showing “HOLD”, “MEM” icon and automatically store with serial numbers. If storage is full, the tester will display “FULL” icon, and then press button to remove lock.

As shown in the left figure below:The lock measurement data of soil resistivity is 53.38Ωm, as the 28th group of data storage.

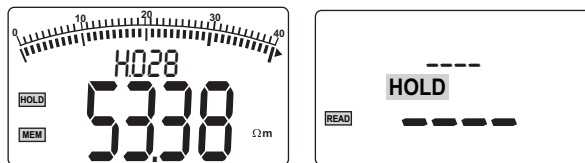

12. Data Reading / Deletion :

In test mode, press “MEM” button for a longer time (over 3 seconds) to enter data reading, press “▲” or “▼” button to select reading data group number by step value 1, press “▲” or “▼” button constantly to select reading data group number by step value 10. When the current data is earth resistance or soil resistivity, press “SET” button to read data value of rC, rP and a, then press “MEM” button to exit from reading.

On reading if there is no storage data, LCD will display “----”, see the above right figure.

Under data reading status, press “CLR” button to enter data deletion, press “▲” or “▼” to select “no” or “yES”, selecting “no” and then pressing “CLR” button for not deleting and return data reading status, selecting “yES” and then pressing “CLR” button for deleting stored data and it will show as above right figure after deletion.

Notice : Operating data deletion will delete all the stored data one-time, and unable to be restored. Please careful operation.

13. Data Upload :

The stored data can be uploaded to computer. Make good connection of computer with RS232 communication wire of the tester, switch on the tester and run monitoring software, and if the software displays that interface is open and the connection is successful, then it can read the stored historical data, upload to company and preserve.

Monitoring software has the function of online real-time monitoring and historical inquiry, dynamic display, with alarm value settings and alarm indicator, and the function of historical data access, reading, preserve, print and other functions.

VII. BATTERY REPLACEMENT :

	Please don't replace battery in flammable spot.
	Please don't replace battery during measurement.
	Pay attention to battery polarity and specification, and don't mix use of new and used battery to avoid damage on tester.
	When the enclosure of Tester is wet, please do not open battery cover.
	Please put the used batteries in appointed collection place.

1. Switch off; making sure that the Tester is under switch-off state.
2. Loosen the four screws on battery cover at the bottom of the Tester, and open battery cover.
3. Replace new battery, pay attention to battery polarity and specification, close battery cover, and fasten screw.
4. Switch on verification, otherwise re-operate.

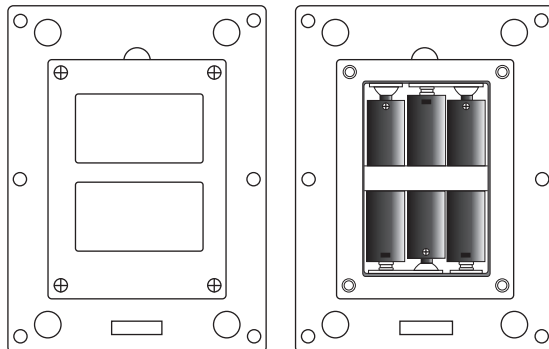

VIII. ACCESSORIES :

Tester	1 PC
Tester Bag	1 PC
Auxiliary Earthing Rod	4 PCS
Standard Testing Wire	4 wires : each for red 20m, black 20m, yellow 10m, and green 10m
Simple Testing Wire	2 wires : each for red 1.6m and black 1.6m
Zinc-manganese Dry Battery	6 PCS (R14S 1.5V)
Monitoring Software Disk	1 Copy
RS232 Communication Cable	1 PC
Manual/Warranty Card/Qualification Certificate	1 Copy

MUMBAI

TEST CERTIFICATE

**EARTH RESISTANCE
SOIL RESISTIVITY TESTER**

This Test Certificate warrants that the product has been inspected and tested in accordance with the published specifications.

The instrument has been calibrated by using equipment which has already been calibrated to standards traceable to national standards.

MODEL NO. **KM 1320**

SERIAL NO. _____

DATE: _____

**ISO 9001
REGISTERED**



WARRANTY

Each "KUSAM-MECO" product is warranted to be free from defects in material and workmanship under normal use & service. The warranty period is one year (12 months) and begins from the date of despatch of goods. In case any defect occurs in functioning of the instrument, under proper use, within the warranty period, the same will be rectified by us free of charges, provided the to and fro freight charges are borne by you.

This warranty extends only to the original buyer or end-user customer of a "KUSAM-MECO" authorized dealer.

This warranty does not apply for damaged IC's, fuses, burnt PCB's, disposable batteries, carrying case, test leads, or to any product which in "KUSAM-MECO's" opinion, has been misused, altered, neglected, contaminated or damaged by accident or abnormal conditions of operation or handling.

"KUSAM-MECO" authorized dealer shall extend this warranty on new and unused products to end-user customers only but have no authority to extend a greater or different warranty on behalf of "KUSAM-MECO".

"KUSAM-MECO's" warranty obligation is limited, at option, free of charge repair, or replacement of a defective product which is returned to a "KUSAM-MECO" authorized service center within the warranty period.

THIS WARRANTY IS BUYER'S SOLE AND EXCLUSIVE REMEDY AND IS IN LIEU OF ALL OTHER WARRANTIES, EXPRESS OR IMPLIED, INCLUDING BUT NOT LIMITED TO ANY IMPLIED WARRANTY OF MERCHANTABILITY OR FITNESS FOR A PARTICULAR PURPOSE. "KUSAM-MECO" SHALL NOT BE LIABLE FOR ANY SPECIAL, INDIRECT, INCIDENTAL OR CONSEQUENTIAL DAMAGES OR LOSSES, INCLUDING LOSS OF DATA, ARISING FROM ANY CAUSE WHATSOEVER.

All transactions are subject to Mumbai Jurisdiction.